

8. Exploded view

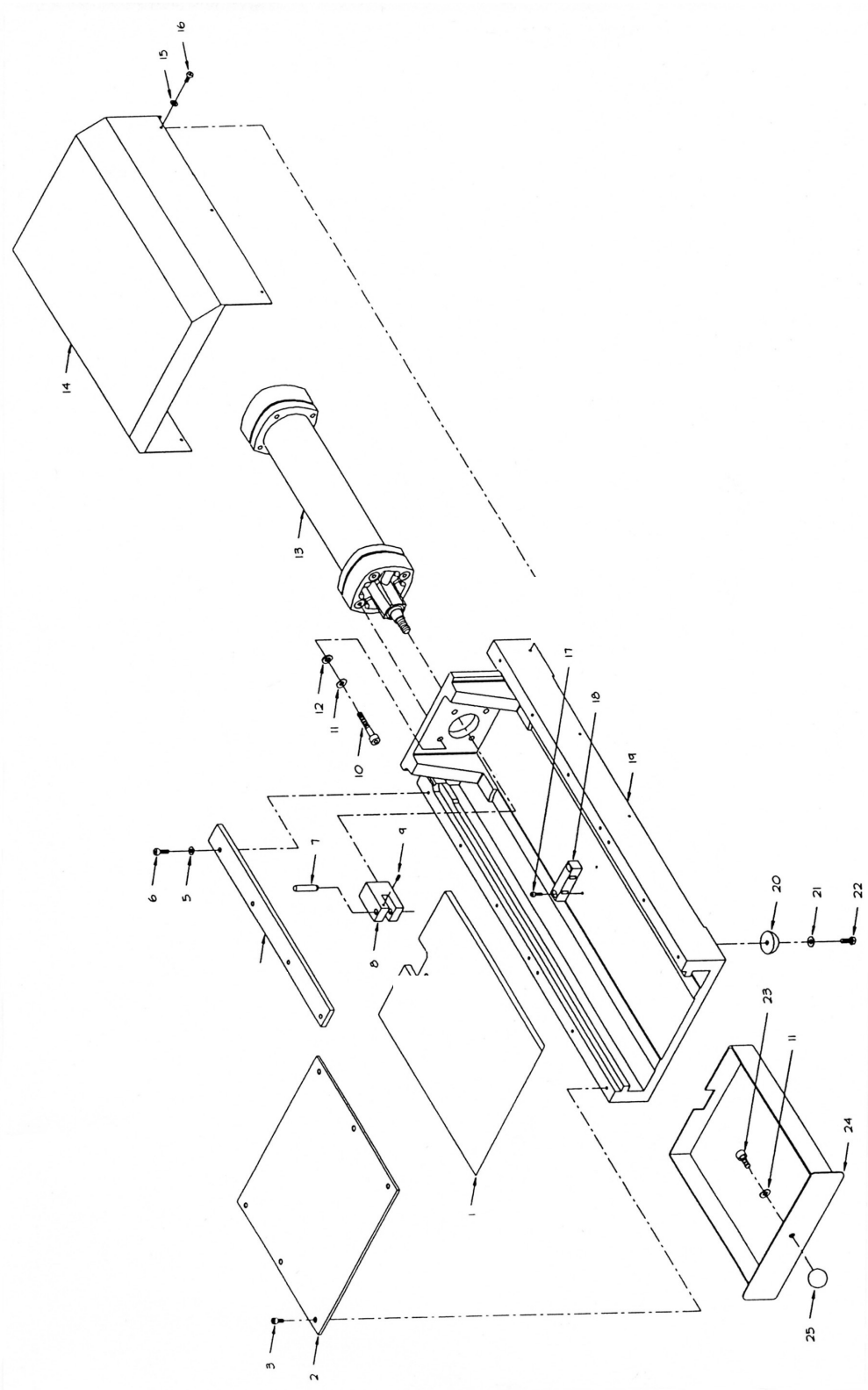

9. Bill of material C058

Pos.	Designation	Part number	Quantity
1*	Cutting blade	T. 020	1
2*	Cutting plate	T. 013	1
3	Hex. socket screws M4x8		6
4	Guide strips	T. 007	2
5	Washers M4		8
6	Hex. socket screws M4x12		8
7	Pin 6x30		1
8	Fork head	T. 010	1
9	Hex. socket pin M3x8		1
10	Hex. socket screws M6x35		4
11	Circlips M6		5
12	Washers M6		4
13*	Compressed air cylinder with screw connection	DNC-50-200-PPV	1
14	Protective hood	T. 016	1
15	Washers M3		6
16	Pan-head screws M3x6		6
17	Hex. socket screws M3x12		2
18	Magnet for waste container		1
19	Base body	T. 001-006	1
20*	Rubber feet with assembly parts		4
21	Washers M5		4
22	Pan-head screws M5x12		4
23	Hex. socket screws M6x10		1
24	Waste container with ball head	T. 015	1
25	Plastic button		1
26	Foot switch, complete	F 5 1/4 B	1
27	Hose, silver 2x2 m		1

Spare parts are marked *