

TP-6000
CUT and BEND

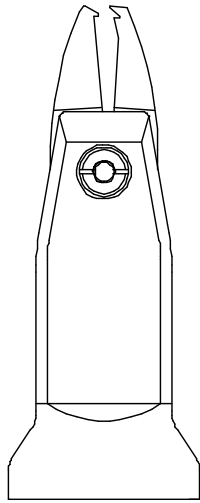

TP-6000-15
CUT and BEND

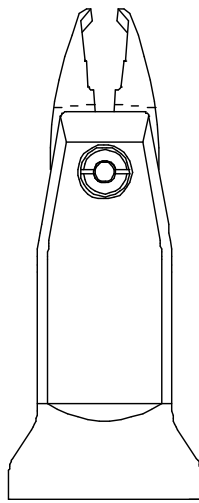

TR-6000-V
60° CUT

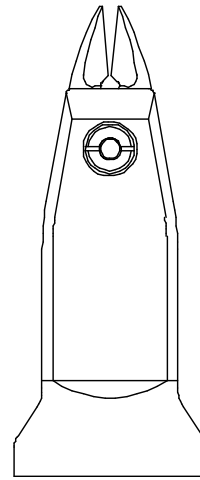

TR-6000
CUT

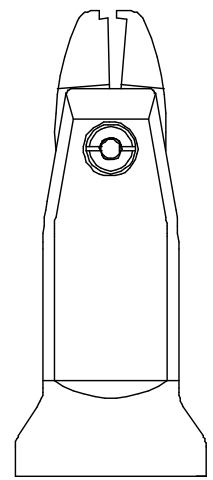

TS-6000
CUT and CRIMP

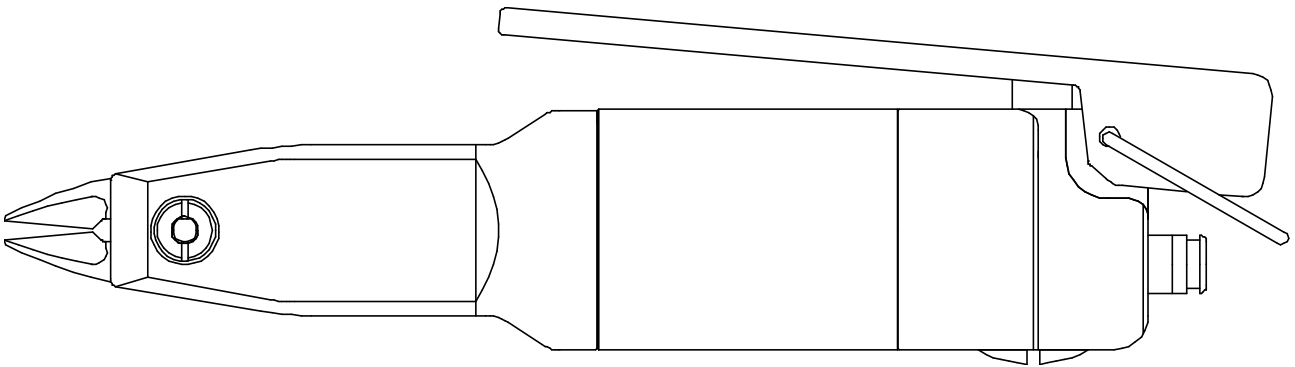

INSTRUCTION MANUAL

TPP

REV. 07

INDEX OF CHAPTER

This manual contains the following information:

- Chapter 1 – Page 3 – Safety symbol and rules to observe
 - Chapter 2 – Page 4 – Introduction
 - Chapter 3 – Page 5 – Components parts
 - Chapter 4 – Page 7 – Blade specifications
 - Chapter 5 – Page 10 – Using the tool
 - Chapter 6 – Page 13 – Servicing and maintenance
 - Chapter 7 – Page 14 – How to change blades
 - Chapter 8 – Page 15 – Optional accessories
 - Chapter 9 – Page 15 – Characteristics
- Page 16 – Conformity Declaration

NOTICE

The manufacturer reserves the right to change or modify the information contained in this manual at any time without prior warning.

1. SAFETY SYMBOLS AND RULES TO OBSERVE



Before any kind of adjustment or registration to be performed on the device, be sure the compressed air supply system is not connected.

WARNING!!! Piergiacomini Sud S.r.l. refuses all responsibilities for any damage caused to operators if the device's chassis has been removed or modified; therefore it is strictly forbidden to perform any maintenance or registration while the device is in use.



- This type of symbol on the tool means: **"DO NOT PUT YOUR HANDS"** between the blades of the tool during operation.



- Always use protective glasses while the tool is operating.
- Turn off the compressed air supply each time the tool is lean on without using it.
- After use place the tool in a safety location and disconnect it from the compressed air supply system.
- Observe and carry out the indications and warnings shown on the special stickers on the tool.

2. INTRODUCTION

2.1 TR-6000 – TR-6000-V

Piergiacomini has become aware of the enormous problems associated with staff that, during the working day, carry out multiple cutting operations, in any sector, from electronics to the plastic or rubber industry. We have studied the problem and obtained the TR-6000, thanks to our vast experience in industry tools, the ideal lightweight tool and with reduced costs.

Furthermore, it's available the TR-6000-V model too, which has a flush front 60° angled cut, in order to have the access in difficult points.

This is the basis of our philosophy and our product has been designed to meet both performance and safety requirements.

Example: At the end of the component mounting stage of an electronic printed circuit board, the requirement of cutting multiple leads without causing damage to the components is needed. Therefore the most qualified solution is to carry out in a fast and efficiently way flush or chamfered cut or a cut at different heights.

With the wide range of types of tips we enable you to reach normally not much accessible parts as shown in the diagram.

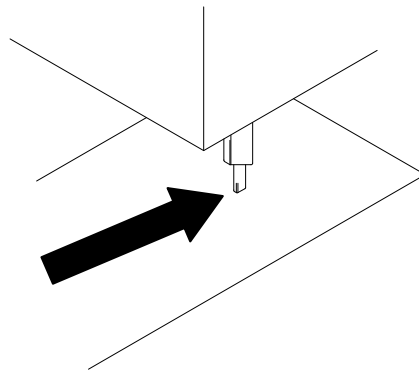

In the plastic sector, as in that of rubber, cutting the parts without causing damage, when removing the excess material created by the moulds, is a common problem. –The TR-6000 model is suitable for cutting small diameters of rubbering material. For cutting bigger diameters, Piergiacomini developed several solutions, like the TPP-TM-6000.

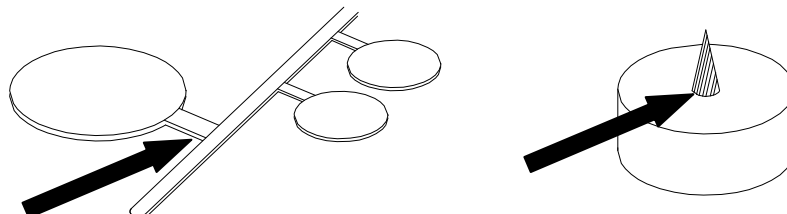

2.2 TP-6000 - TP-6000-15 - TS-6000

Those who work in the electronics sector frequently have the problem of blocking the components on the printed circuit board before and during the soldering phase. In order to solve the problem, Piergiacomini has designed and produced these tools, the TP-6000, which cuts the component leads and bends them so as to fix them firmly in place to the board. The operator that will later perform the soldering phase will therefore not have that troublesome problem of components that have been displaced or in the worst case become loose and fallen off the board.

The TP-6000 or TP-6000-15 proves to be an enormously special tool as it manages to carry out two functions in one operation and furthermore has the advantages of being a lightweight and reduced costs pneumatic tool.

This is the basis of our philosophy and our product has been designed to meet both performance and safety requirements.

3. COMPONENTS PARTS

The main characteristic of the TPP is the possibility to interchange the fix base (body) TPP, as shown in the Fig. 1 with the several heads or with specific blades for the required work. Every time a change of works is needed, it's enough to replace, in a simply and fast way, the upper part (head) of the tool. See instructions on Chapter 7.

Example of part number: TPP-TP-6000

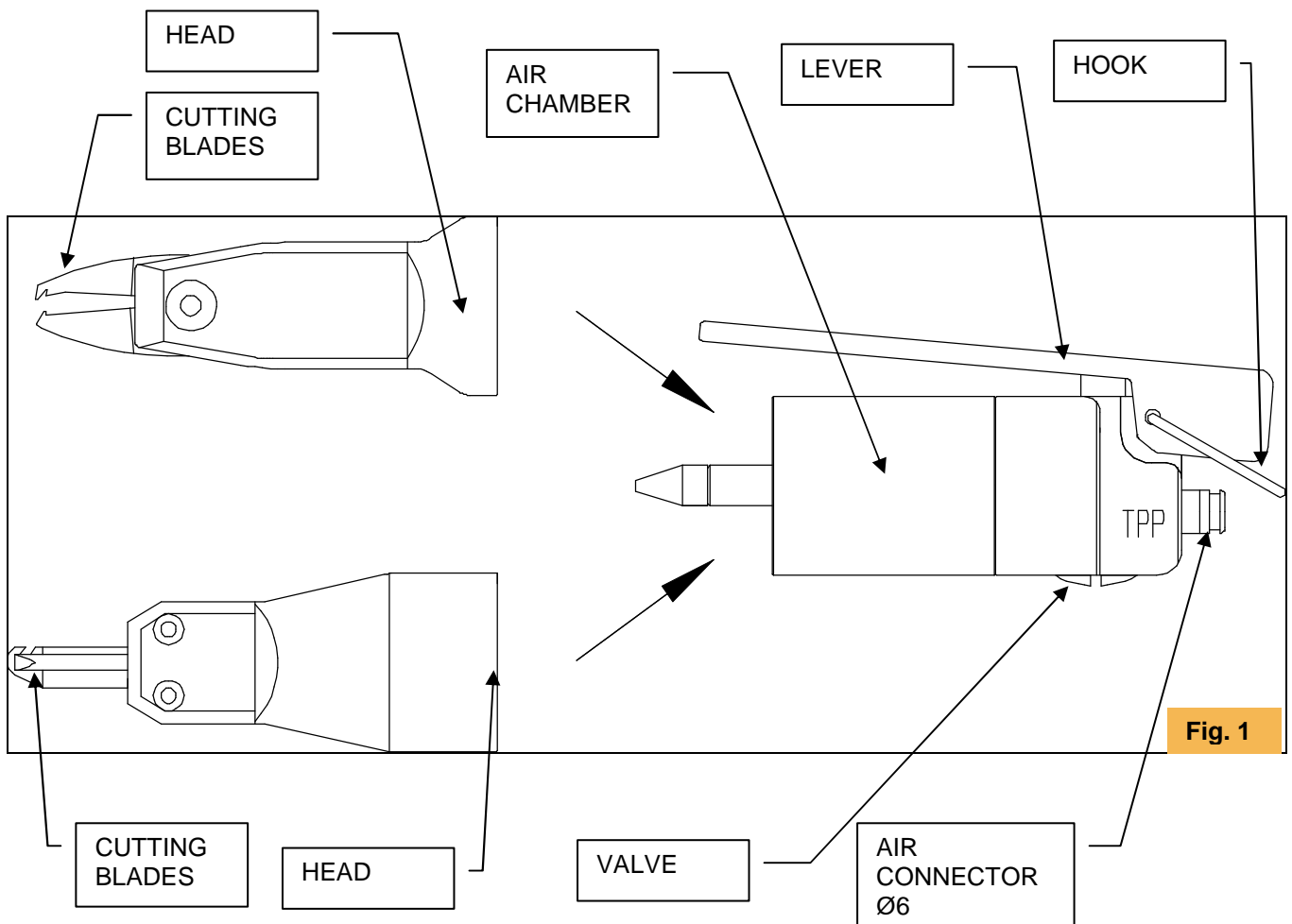
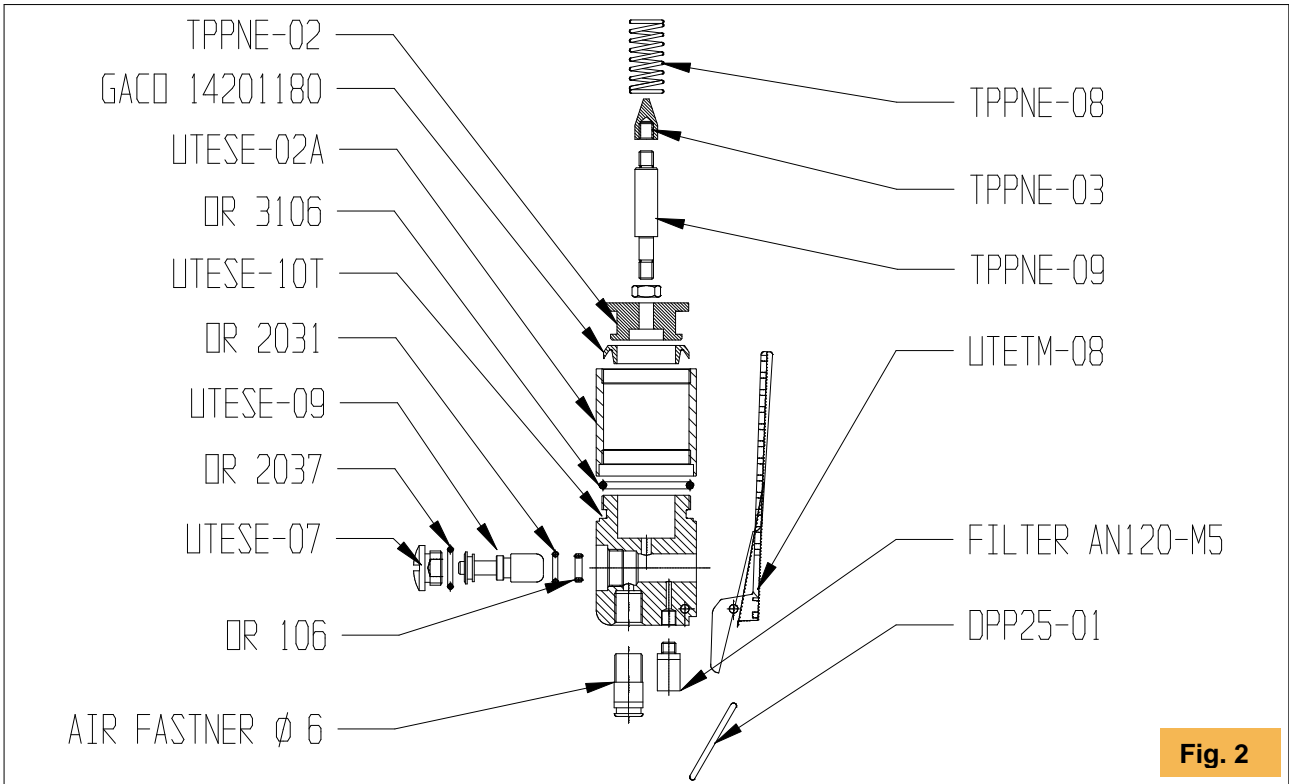
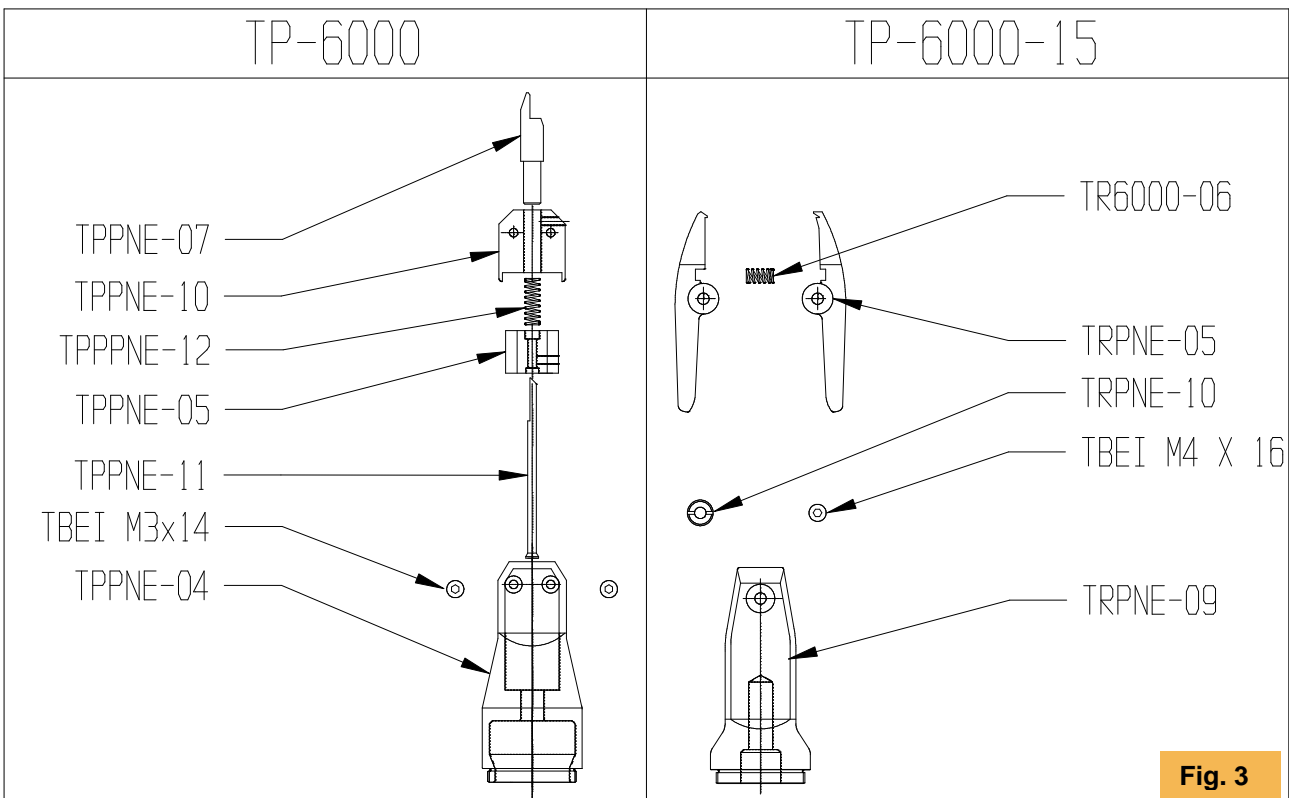

Fig. 1

3.1 TPP



3.2 TP-6000 TP-6000-15



3.3 TR-6000 TR-6000-V TS-6000

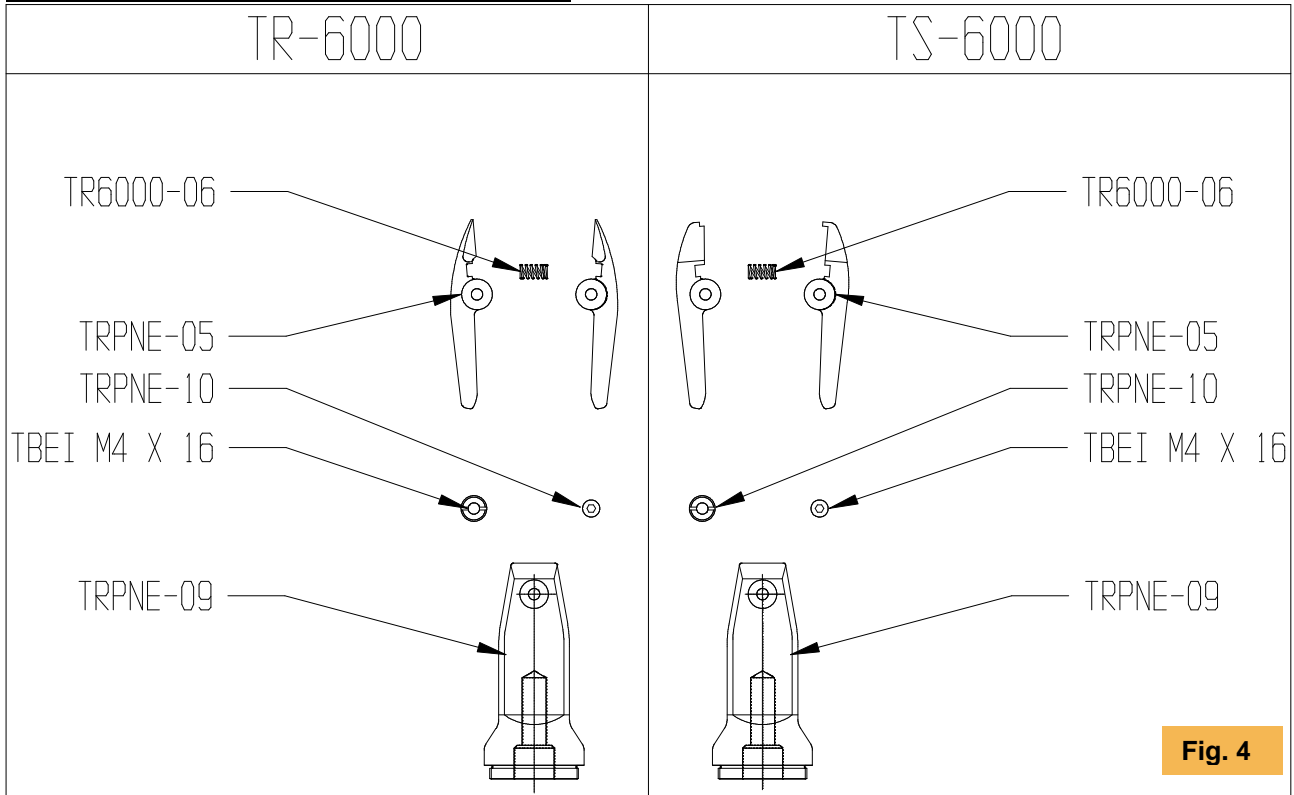

Fig. 4

4. BLADE SPECIFICATIONS

The blades are made from grinded & tempered special steel and can be easily replaced, as explained in Chapters 7 of this manual.

- TP-6000

Cut & Bend blades for blocking the leads of the component on the PCB. (Max cut 1.02 mm)

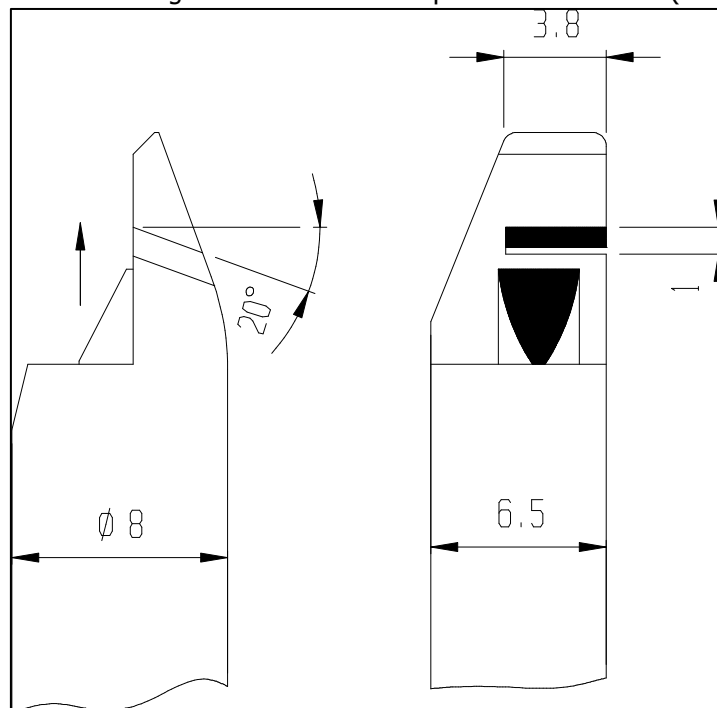
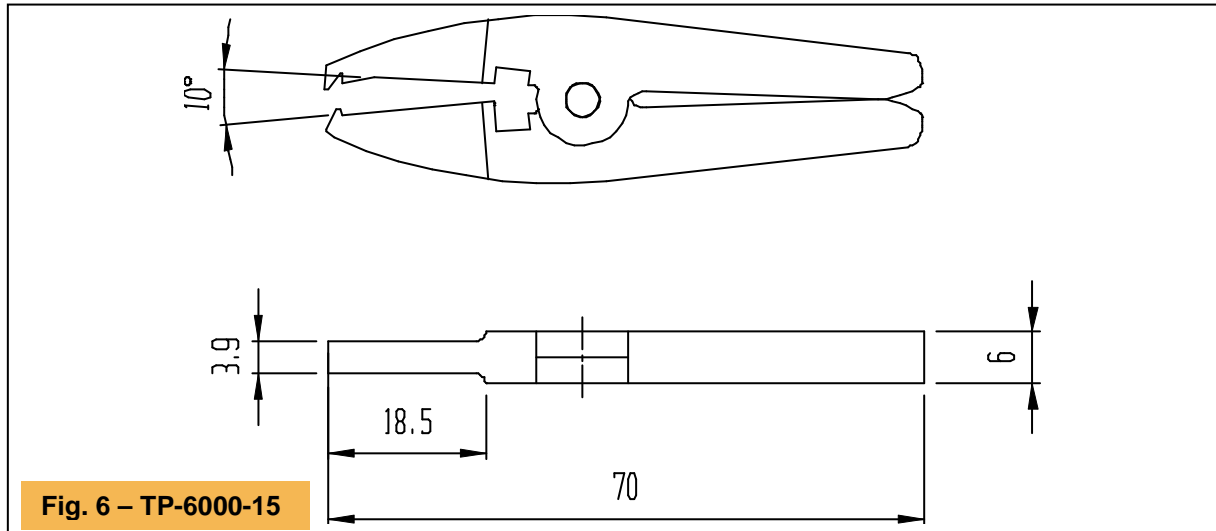

Fig. 5 – TP-6000

- **TP-6000-15**

Cut and Bend Blades for blocking the leads of the component on the PCB, to reach very dense areas.
(Max cut 1.02 mm)



- **TR-6000**

Blades TR-6000 are supplied standard with 2 typology of cuts (Fig. 7):

- **CHAMFERED (code TR-6000):** permit also to cut harder components & a number of unlimited cuts without damaging the blades.

- **FLUSH (code TR-6000-R):** permit to make flush and precise cuts. Suggested in particular where a absolute accuracy of cut is needed.

Flush cut Chamfered cut

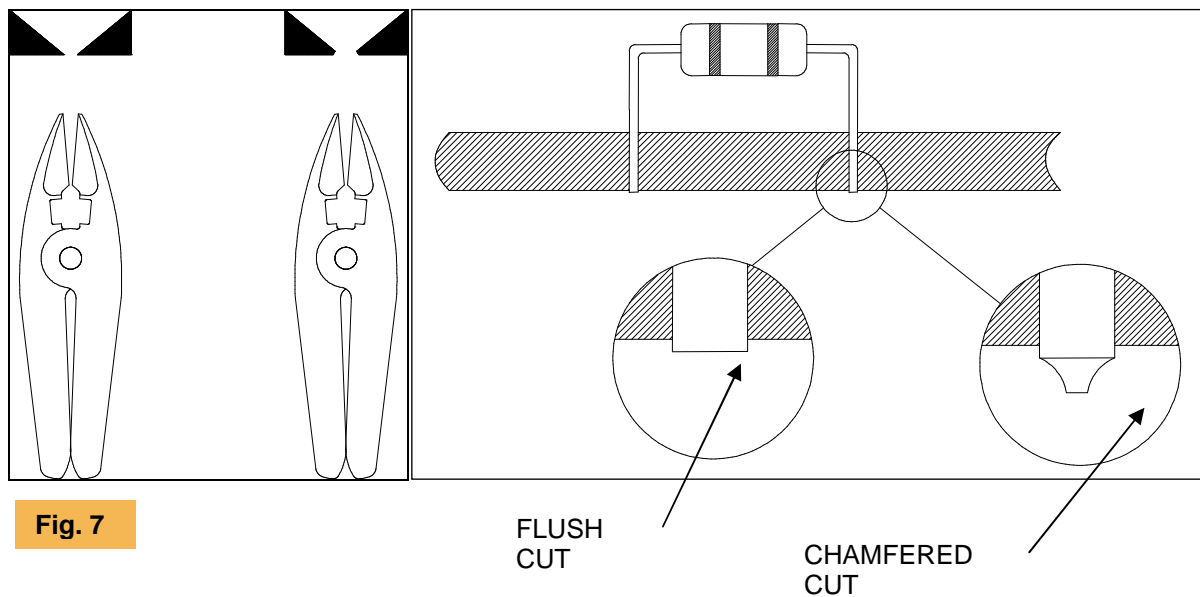

TR-6000 blade (chamfered cut, Max cut 1.6 mm, Fig. 5) is available in different versions, as shown on our catalogues:

- **TR-6000 R** (Max cut 1.6 mm) with flush cut.
- **TR-6000 PR** (Max cut 1.3 mm) with flush cut, but more pointed tips.
- **TR-6000 10/13/15** (Max cut 1.6 mm) with flush cut at different height (1.0mm, 1.3mm & 1.5mm) from the surface.
- **TR-6000 C** (Max cut 1.6 mm) with shorter and stronger blades.

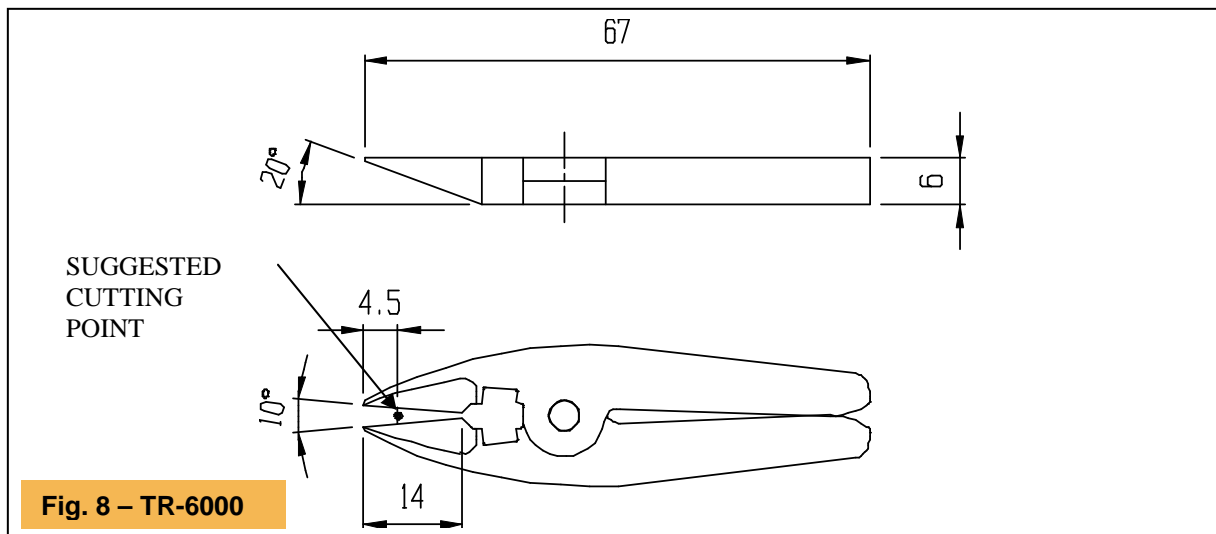

- **TR-6000-V**
Flush front 60° angled blades, in order to have the access in difficult points.(Max cut 1.3 mm).

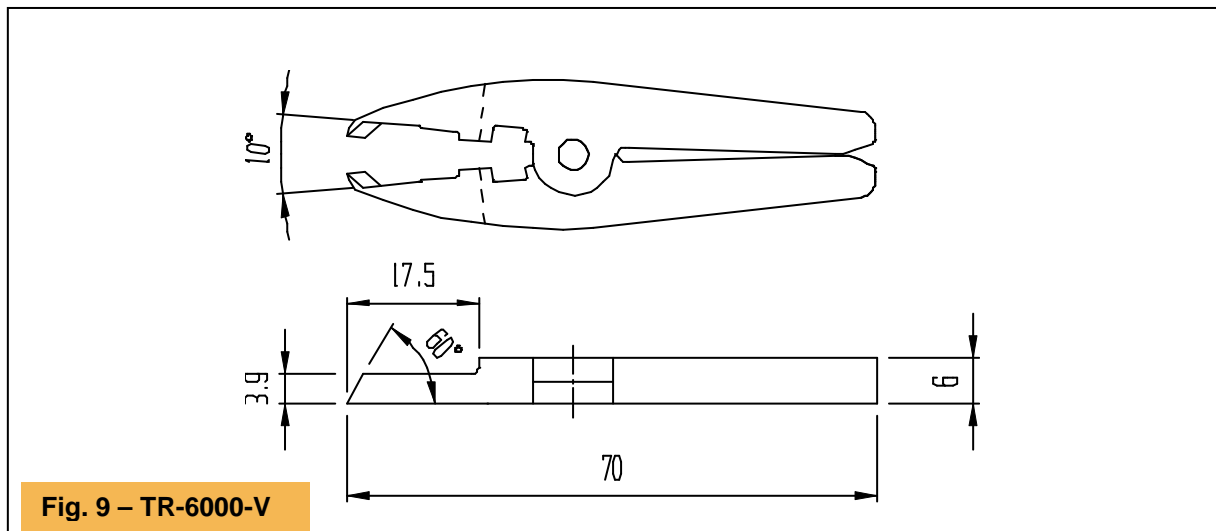

- **TS-6000**

Cut & Press blades, for blocking the leads of the component on the PCB. (Max cut 1.3 mm).

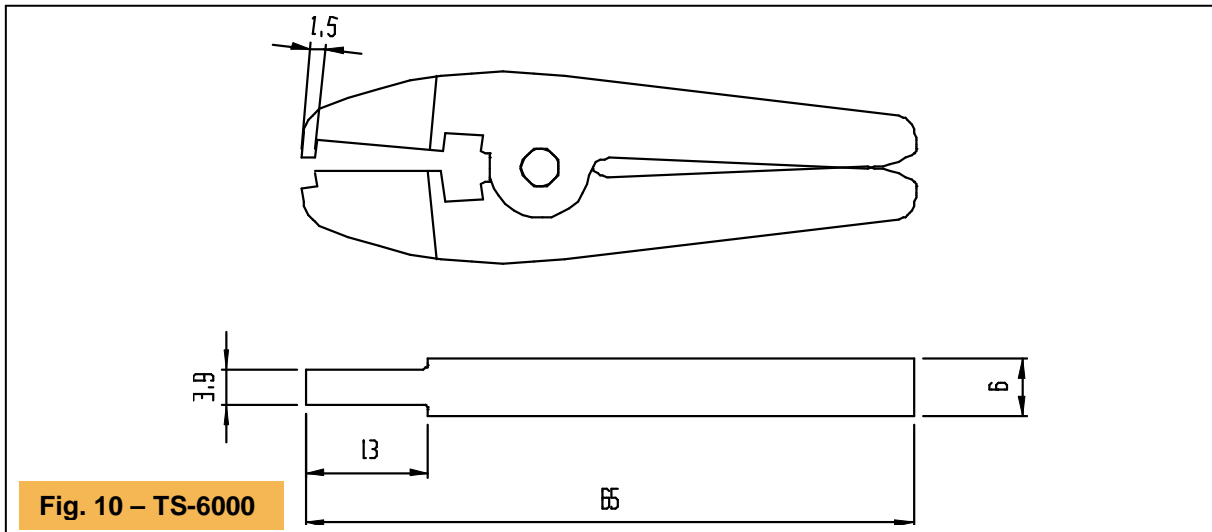

Fig. 10 – TS-6000

Special blades suitable for your purposes are produced at request!

5. USING THE TOOL

Before using this device, read carefully Chapter 1 (Safety Symbols and Rules to observe).



Warning! Always wear protective glasses during the use of the tool and do not work with your fingers close to the blades while moving.

Warning! After using, put device in a safety place and disconnect compressed air supply system.

The tool should be used at the angle shown in the figures with respect to the working surface.

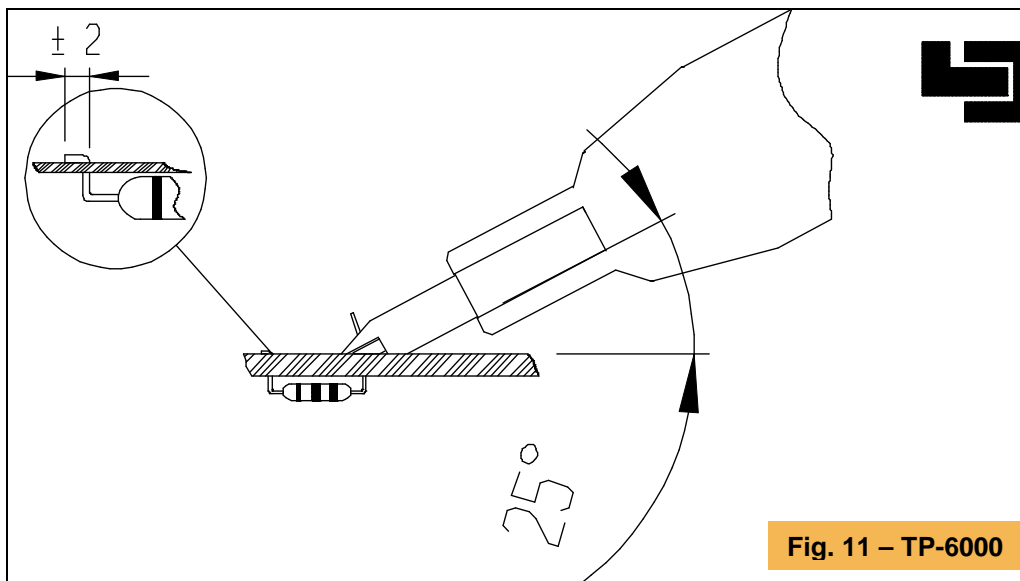

Fig. 11 – TP-6000

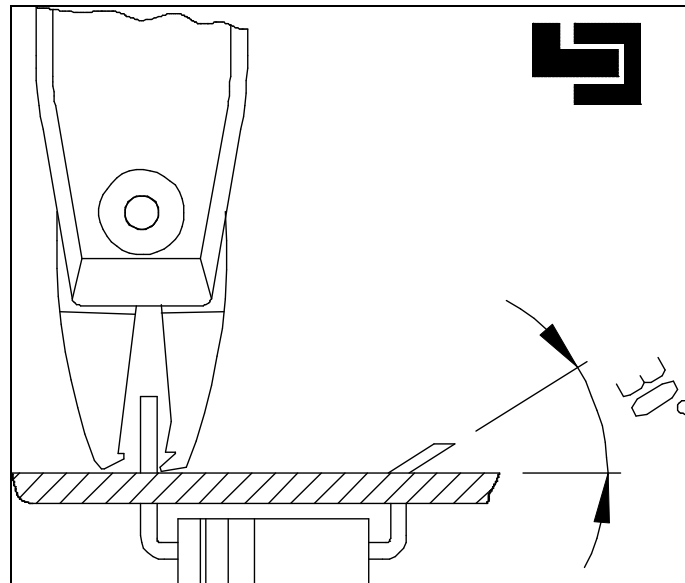

Fig. 12 – TP-6000-15

TR-6000 : The most suggested point for cutting is situated at about 1/3 of the cutting length (see Cap.4 Fig. 8).

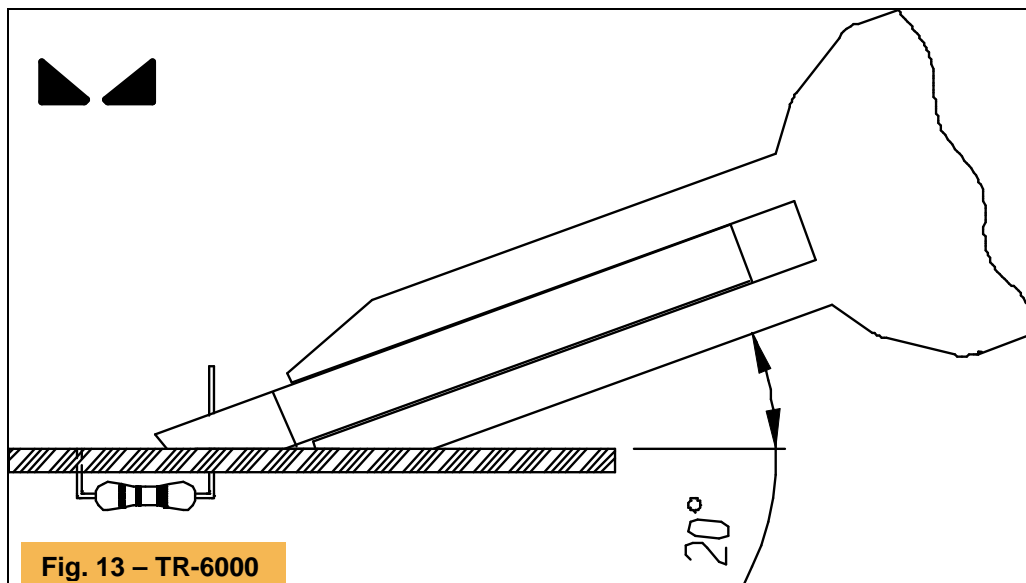

Fig. 13 – TR-6000

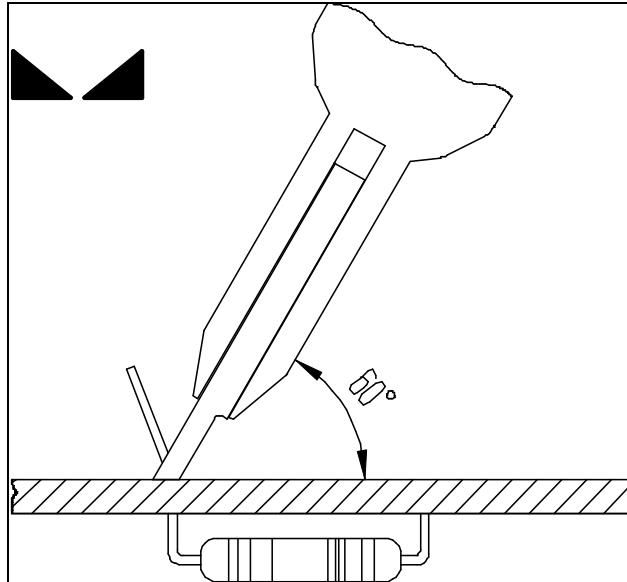

Fig. 14 – TR-6000-V

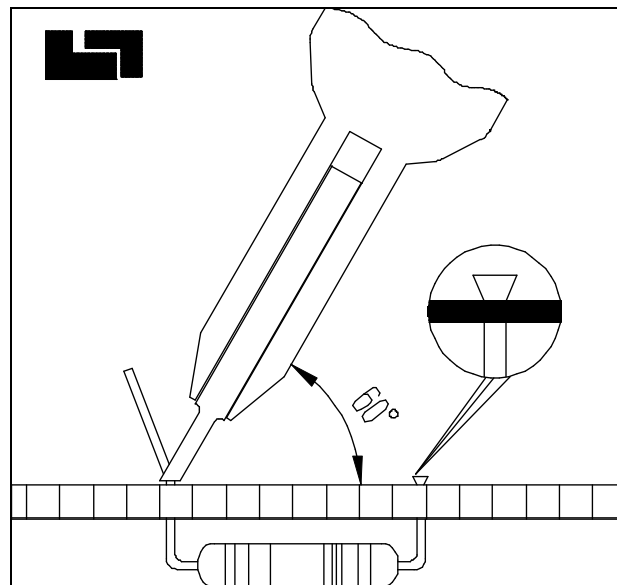
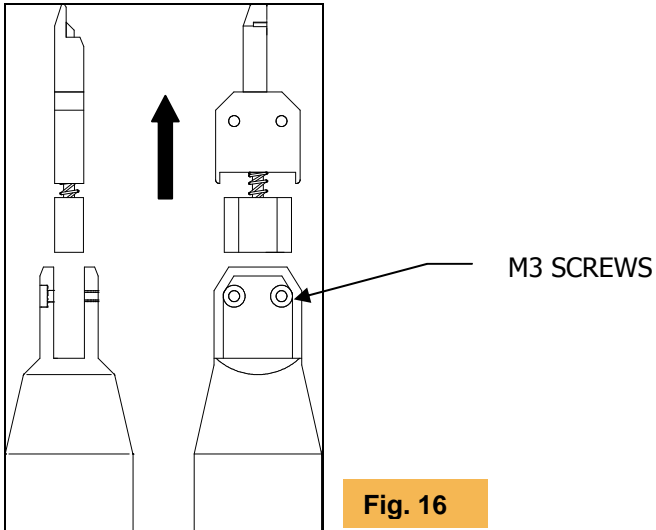

Fig. 15 – TS-6000

6. HOW TO CHANGE BLADES

6.1 TP-6000



- Use the supplied hexagonal key to remove the M3 screw on the head and take out the blade set. (Fig.16)
- For reassemble the blade, insert the blade set as indicated on the Fig. 16 and fasten screw M3.



Warning!

During blade removal, make sure the compressed air supply is shut off.

6.2 TP-6000-15 - TR-6000 - TR-6000-V - TS-6000

- Use the supplied hexagonal key & a slotted screwdriver to remove the ring nut and the M4 screw as indicated on Fig. 17 and take out blades.

- For reassemble the blades follow below phases:

- 1) Insert on screw M4 some thread docking adhesive.
- 2) Insert blades on the head and fix M4 screw.
- 3) Hold blades closed by one hand and fasten the M4 fasten until the blades are blocked.
- 4) Fasten the ring nut.
- 5) Lightly unscrew the M4 screw, until blades are autonomously open.

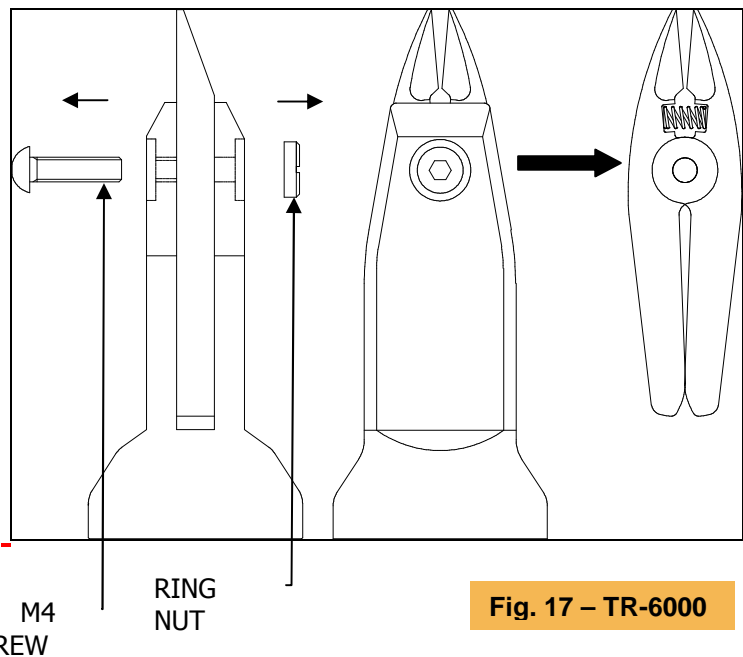

Warning!

During blade removal, make sure the compressed air supply is shut off.

7. SERVICING AND MAINTENANCE

7.1 NORMAL SERVICING

DAILY :

Remove any residual cut material found between the gaps in the head with a compressed air gun.

7.2 SPECIAL SERVICING

EVERY 4 MONTHS :

Lubricate the air seals with vaseline oil following the instructions.

- 1 Remove the compressed air feed tube, put one cubic centimetre of oil in the air connector as shown in the Fig.18;
- 2 Reconnect the compressed air supply tube to the tool and activate the tool several times to permit the oil to enter in circulation; if the blade slides freely, the lubrication has been a success, otherwise repeat stage 1.

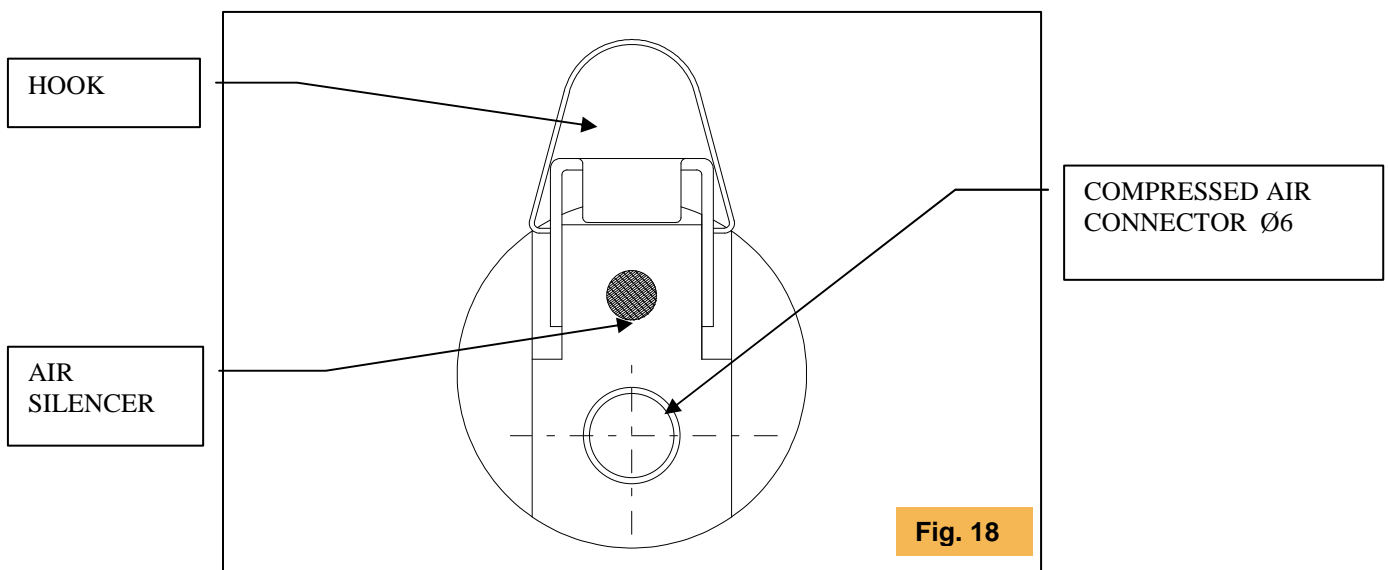

8. OPTIONAL ACCESSORIES

The following parts can be supplied as optional:

- 1- Pedal control system + special valve.

9. CHARACTERISTICS

Characteristics:

Air pressure :	6 - 7 bar
Consumption :	3,5 NI/min
Blade material :	Tempered steel
Blade thickness :	6 mm standard
Type of cut :	Flush o Chamfered (TR-6000)
Type of bend :	90° (TP-6000) or 30° (TP-6000-15)
Max cut :	1 mm (TP-6000, TP-6000-15) 1.3 mm (TS-6000, TR-6000 PR, TR-6000-V) 1.6mm (TR-6000, TR-6000-C, TR-6000-10/13/15)
Approximate dimensions:	165 x 35 mm
Weight :	300 g.

TECHNICAL ASSISTANCE OFFICE:

PIERGIACOMI SUD SRL
VIA 81A STRADA 3, FRAZ CENTOBUCHI,
63076 MONTEPRANDONE (AP) ITALY
tel. +39 0735 703 333
fax +39 0735 703 757

COMMERCIAL OFFICE:

PIERGIACOMI SUD SRL
Via Gramsci 3 - 60022 Castelfidardo (AN) Italy
tel. +39 071 78678-780 211
fax +39 071 7822 536

www.piergiacomini.com
piergiacomini@piergiacomini.com - info@piergiacomini.com

DECLARATION OF CONFORMITY

MODELS : **TPP - TR-6000 / TP-6000 / TS 6000**

Pneumatic tool to cut electronic components.

DPP

Pneumatic tool for the depaneling of PCBs.

THE TOOLS **TPP** and **DPP** ARE CONFORM TO THE ESSENTIAL REQUIREMENTS OF THE FOLLOWING STANDARD OR HARMONIZING RULES :

DIRECTIVE 98/31/CE

EN 12100-1 Safety of machinery. Basic concepts, general principles for design.
Part 1 Basic terminology, methodology.

EN 12100-2 Safety of machinery. Basic concepts, general principles for design.
Part 2 Technical principles and specifications.

EN 1050 Safety of machinery. Principles for the risk assessment.

MODELS : **SSF-1 / DPB-1**

Pneumatic depaneling machine with 1 pneumatic head.

SDP

Pneumatic depaneling machine form 1 to 3 pneumatic heads.

THE MACHINES **SSF-1, DPB-1** and **SDP** ARE CONFORM TO THE ESSENTIAL REQUIREMENTS OF THE FOLLOWING STANDARD OR HARMONIZING RULES :

DIRECTIVE 98/37/CE

EN 12100-1 Safety of machinery. Basic concepts, general principles for design.
Part 1 Basic terminology, methodology.

EN 12100-2 Safety of machinery. Basic concepts, general principles for design.
Part 2 Technical principles and specifications.

EN 294 Safety of machinery. Safety distances to prevent danger zones being reached by the upper limbs.

EN 1050 Safety of machinery. Principles for the risk assessment.

Monteprandone li 06 - 05 - 2008

Legal Represent
CARINI ENRICO



Piergiacomì Sud Srl

head office > Via 81° Strada, 3 – I-63076 Monteprandone (AP)
tel. +39-0735-703333 – fax +39-0735-703757

commercial office > Via Gramsci, 3 – I-60022 Castelfidardo (AN)
tel. +39-071-78678 – fax +39-071-7822536
<http://www.piergiacomì.com>
e-mail piergiacomì@piergiacomì.com